

INSTALL (2) 3/4" x 8'-0" LONG GROUND RODS (TO PROJECT 3") ONE FOR GROUNDING INTALOGIX POWER SUPPLY, ONE FOR GROUNDING SCALE WEIGHBRIDGE. POWER SUPPLY GROUND MUST BE SEPARATE FROM WEIGHBRIDGE GROUND. TWO GROUND RODS ARE SUPPLIED WITH SCALE.

1" MIN. CONDUIT (BY OTHERS) FOR CABLE FROM JUNCTION BOX TO SCALEHOUSE. CONDUIT TO EXTEND 2' ABOVE THE TOP OF PIER.

PLAN VIEW

N.I.S.T. H-44 REQUIRES THAT ON THE APPROACH ENDS OF THIS VEHICLE SCALE, THERE SHALL BE A STRAIGHT APPROACH AT LEAST 30 FEET LONG. NOT LESS THAN 10 FEET OF ANY APPROACH ADJACENT TO THE PLATFORM SHALL BE LEVEL AND CONSTRUCTED OF CONCRETE OR SIMILAR DURABLE MATERIAL. ANY SLOPE IN THE REMAINING PORTION OF THE APPROACH SHALL ENSURE EASE OF VEHICLE ACCESS, EASE FOR TESTING PURPOSES, AND DRAINAGE AWAY FROM THE SCALE.

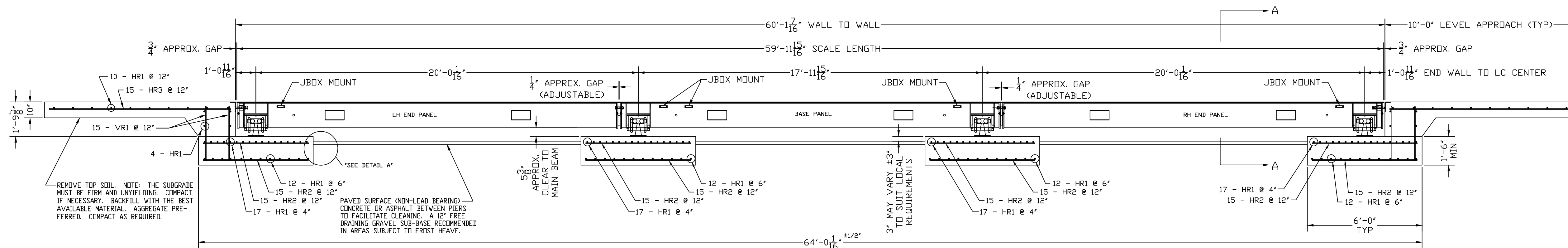

ELEVATION SECTION

NOTES:

1. FOUNDATION SHOWN IS DESIGNED FOR SOILS WITH A MINIMUM BEARING CAPACITY OF 3000 PSF AND ADEQUATE DRAINAGE. IF SOIL CONDITIONS DO NOT MEET THESE REQUIREMENTS, ADJUST FOUNDATION OR SOIL CONDITIONS AS REQUIRED.
2. IN AREAS OF THE COUNTRY WHERE THERE IS SEVERE FREEZING, INCREASE THE DEPTH OF THE FOUNDATION SO THAT THE BOTTOM EXTENDS BELOW THE FROST LINE, OR PROVIDE A MINIMUM OF 12" FREE DRAINING GRANULAR MATERIAL TO PREVENT FROST HEAVE.
3. N.I.S.T. H-44 REQUIREMENTS AND LOCAL WEIGHTS AND MEASURES REGULATIONS MAY REQUIRE INSTALLATION PARAMETERS SOMEWHAT DIFFERENT THAN ILLUSTRATED ON THIS PLAN. IN ORDER TO INSURE COMPLIANCE, CONSULT THE LOCAL WEIGHTS & MEASURES OFFICE PRIOR TO CONSTRUCTION.
4. REFER TO SCALE MANUAL FOR INSTALLATION AND OPERATION INSTRUCTIONS.
5. A MINIMUM OF 24" OF CLEARANCE IS REQUIRED ON JUNCTION BOX SIDE OF THE SCALE NEAR THE BOX MOUNTS.

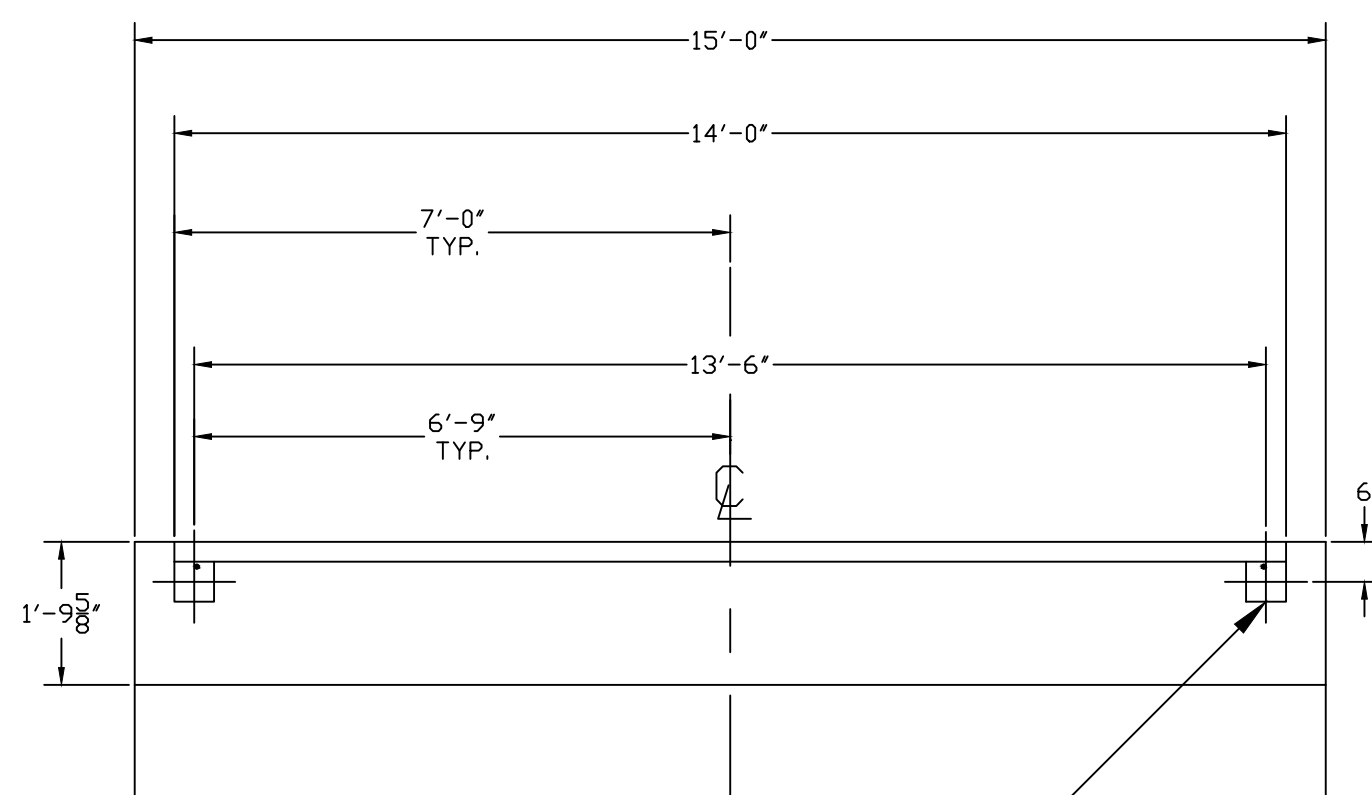
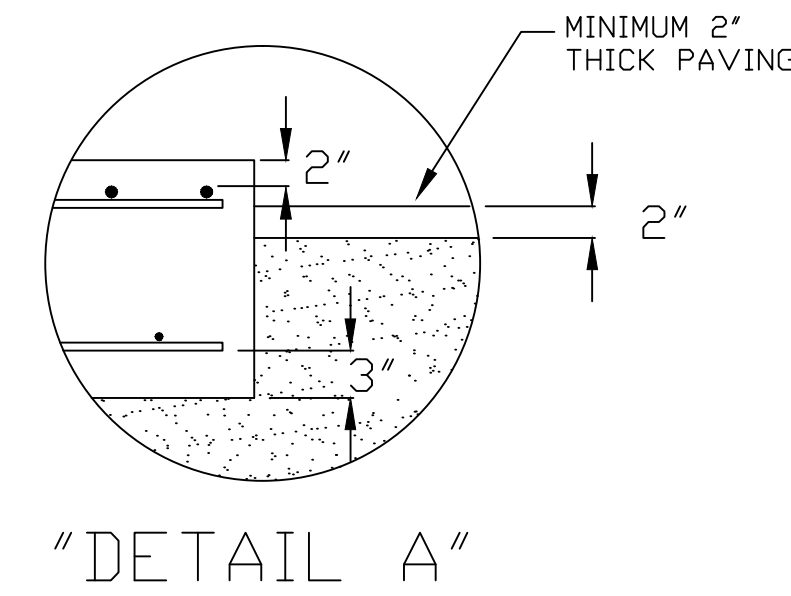

SECTION A-A END WALL/BUMPS

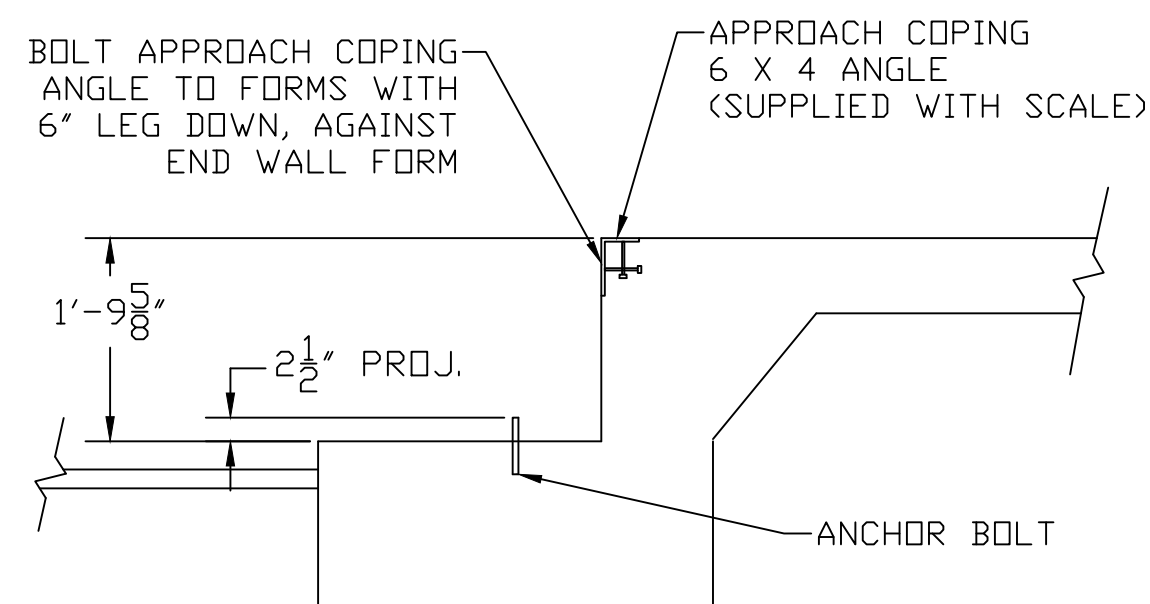

DRILL TYPE ANCHOR INFORMATION (DRILL TYPE ANCHORS PROVIDED WITH THE SCALE)  
 FOR THE LC STANDS (16 REQUIRED)  
 5/8 DIA X 6" STUD TYPE ANCHORS  
 DRILL DIA 5/8", DRILL DEPTH 3 1/2"

ANCHOR DETAIL

FOUNDATION CONCRETE REQUIREMENTS 4000 P.S.I.	
AREA	QUANTITIES
PIERS AS SHOWN	20 CU. YD.
APPROACHES	12 CU. YD.
FLOOR AT 2" THICK	3.5 CU. YD.
<b>TOTAL</b>	<b>35.5 CU. YD.</b>

FOUNDATION REINFORCING BAR SCHEDULE ASTM A615 GRADE 60					
MARK	NO.	REQ'D.	SIZE	LENGTH	WT.
HR1	144	#4	14'-6"		1395
HR2	120	#4	5'-6"		441
HR3	30	#4	9'-6"		190
VR1	60	#4	2'-9"		110
<b>TOTAL WT:</b>					<b>2136</b>

REINFORCING STEEL NOTES:

1. REINFORCING STEEL SHALL BE FREE OF ALL MUD, DEBRIS, CEMENT GROUT, LOOSE RUST, GREASE, AND OIL.
2. TACK WELDING OF BARS IS PROHIBITED.

THIS DRAWING IS SUPPLIED AS CHECKED BELOW:

- REFERENCE (ESTIMATES ONLY, NOT FOR CONSTRUCTION)
- CERTIFIED FOR CONSTRUCTION, THURMAN #
- CUSTOMER: \_\_\_\_\_ DATE: \_\_\_\_\_
- CUSTOMER APPROVAL, RETURN ONE COPY.
- APPROVED AS DRAWN, APPROVED BY: \_\_\_\_\_ DATE: \_\_\_\_\_
- APPROVED AS NOTED, APPROVED BY: \_\_\_\_\_ DATE: \_\_\_\_\_

LET	BY	DATE	REVISION
1	JCR	9/21/11	MOVED BASE MIDDLE TO CENTER OF SCALE



8560 DIAMONDBACK XD  
 130K CLC 60' X 14'  
 FOUNDATION (4 SECTION, DB LC)

DATE	5/13/08	SHEET 1	OF 1
SCALE	N/A	DRAWING NUMBER	92438-FT
DRAWN BY	LDC	REVISION	1