

- NOTES:
- FOUNDATION SHOWN IS DESIGNED FOR SOILS WITH A MINIMUM BEARING CAPACITY OF 3000 PSF AND ADEQUATE DRAINAGE. IF SOIL CONDITIONS DO NOT MEET THESE REQUIREMENTS, ADJUST FOUNDATION OR SOIL CONDITIONS AS REQUIRED.
 - IN AREAS OF THE COUNTRY WHERE THERE IS SEVERE FREEZING, INCREASE THE DEPTH OF THE FOUNDATION SO THAT THE BOTTOM EXTENDS BELOW THE FROST LINE, OR PROVIDE A MINIMUM OF 12" FREE DRAINING GRANULAR MATERIAL TO PREVENT FROST HEAVE.
 - N.I.S.T. H-44 REQUIREMENTS AND LOCAL WEIGHTS AND MEASURES REGULATIONS MAY REQUIRE INSTALLATION PARAMETERS SOMEWHAT DIFFERENT THAN ILLUSTRATED ON THIS PLAN. IN ORDER TO INSURE COMPLIANCE, CONSULT THE LOCAL WEIGHTS & MEASURES OFFICE PRIOR TO CONSTRUCTION.
 - REFER TO SCALE MANUAL FOR INSTALLATION AND OPERATION INSTRUCTIONS.
 - A MINIMUM OF 24" OF CLEARANCE IS REQUIRED ON JUNCTION BOX SIDE OF THE SCALE NEAR THE BOX MOUNTS.

FOUNDATION CONCRETE REQUIREMENTS 4000 P.S.I.	
AREA	QUANTITIES
PIERS AS SHOWN	17.5 CU. YD.
APPROACHES	10.5 CU. YD.
FLOOR AT 2" THICK	4 CU. YD.
TOTAL	32 CU. YD.

FOUNDATION REINFORCING BAR SCHEDULE ASTM A615 GRADE 60					
MARK	NO.	REQ'D.	SIZE	LENGTH	WT.
HR1	144	#4	12'-6"	1202	
HR2	104	#4	5'-6"	382	
HR3	26	#4	9'-6"	165	
VR1	52	#4	2'-9"	96	
TOTAL WT: 1845					

REINFORCING STEEL NOTES:
 1. REINFORCING STEEL SHALL BE FREE OF ALL MUD, DEBRIS, CEMENT GROUT, LOOSE RUST, GREASE, AND DIL.
 2. TACK WELDING OF BARS IS PROHIBITED.

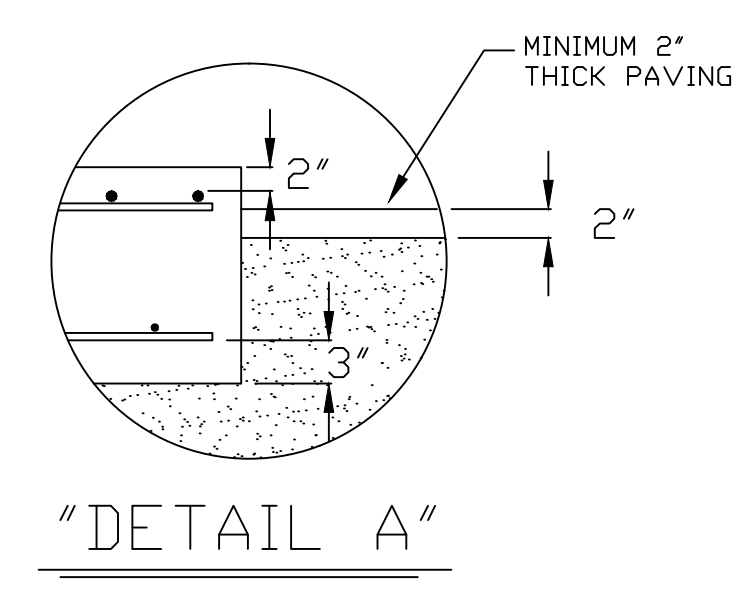
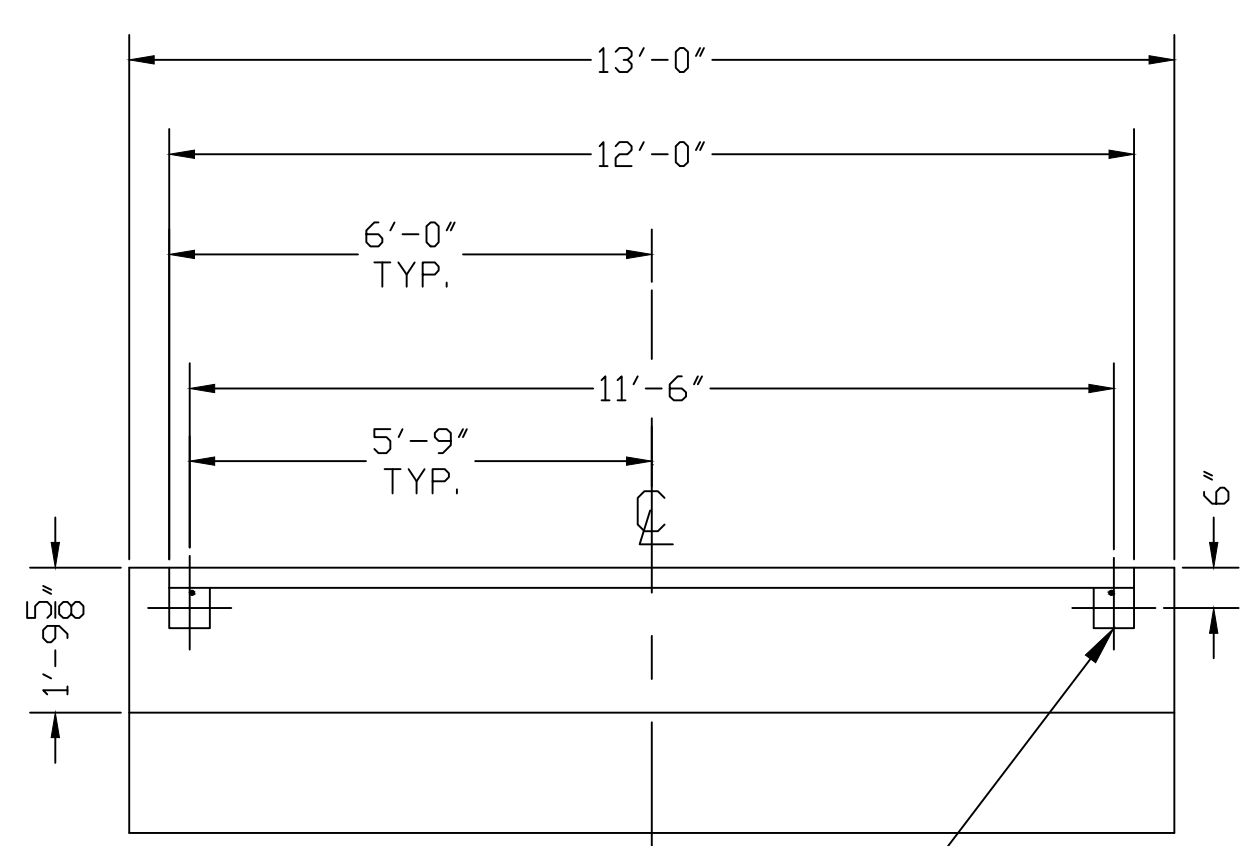
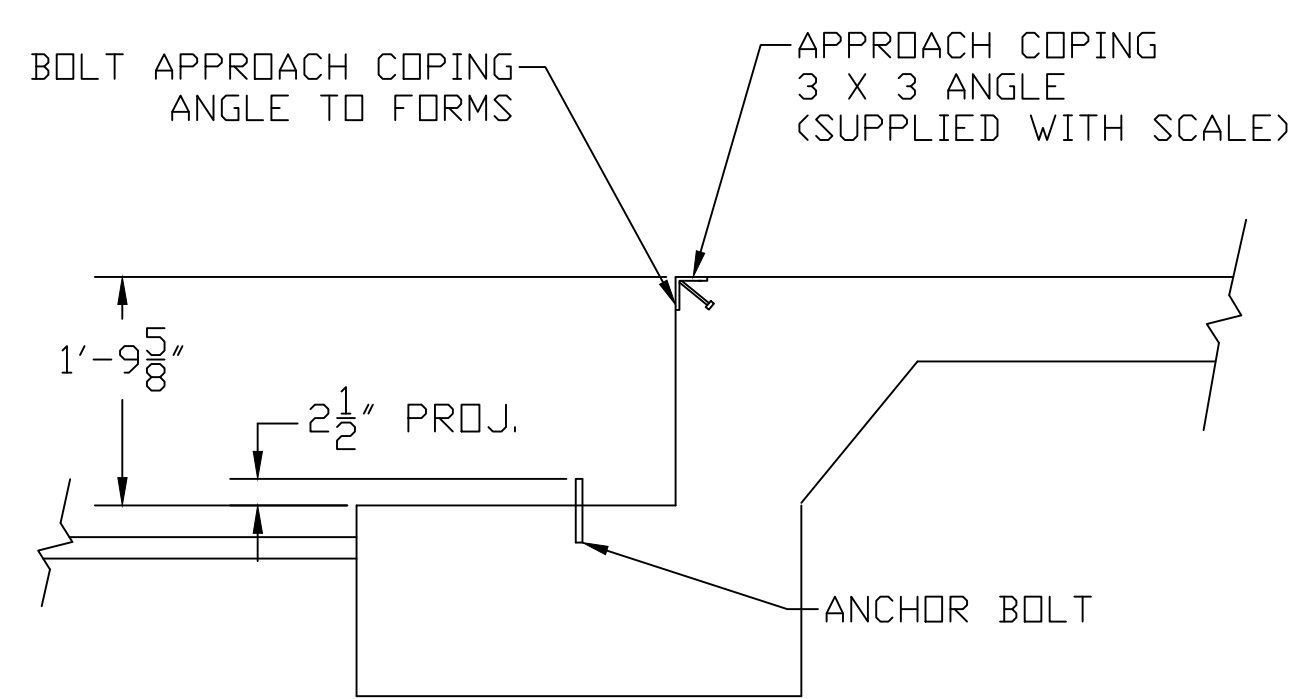

THIS DRAWING IS SUPPLIED AS CHECKED BELOW:
 REFERENCE (ESTIMATES ONLY, NOT FOR CONSTRUCTION)
 CERTIFIED FOR CONSTRUCTION, THURMAN #
 CUSTOMER: _____ DATE: _____
 CUSTOMER APPROVAL, RETURN ONE COPY.
 (ORDER ON HOLD UNTIL SIGNED COPY IS RETURNED)
 APPROVED AS DRAWN, APPROVED BY: _____ DATE: _____
 APPROVED AS NOTED, APPROVED BY: _____ DATE: _____

LET	BY	DATE	REVISION
1	JCR	9/21/11	MOVED BASE MIDDLE TO CENTER OF SCALE

THURMAN SCALE
 COLUMBUS, OH

8560 DIAMONDBACK XD
 130K CLC 70' x 12'
 FOUNDATION (4 SECTION, DB LC)

DATE: 6/23/08
 SCALE: N/A
 DRAWN BY: NDC
 SHEET 1 OF 1
 DRAWING NUMBER: 92441-FT
 REVISION: 1