

NOTES:

1. FOUNDATION SHOWN IS DESIGNED FOR SOILS WITH A MINIMUM BEARING CAPACITY OF 3000 PSF AND ADEQUATE DRAINAGE. IF SOIL CONDITIONS DO NOT MEET THESE REQUIREMENTS, ADJUST FOUNDATION OR SOIL CONDITIONS AS REQUIRED.
2. IN AREAS OF THE COUNTRY WHERE THERE IS SEVERE FREEZING, INCREASE THE DEPTH OF THE FOUNDATION SO THAT THE BOTTOM EXTENDS BELOW THE FROST LINE, OR PROVIDE A MINIMUM OF 12" FREE DRAINING GRANULAR MATERIAL TO PREVENT FROST HEAVE.
3. N.I.S.T. H-44 REQUIREMENTS AND LOCAL WEIGHTS AND MEASURES REGULATIONS MAY REQUIRE INSTALLATION PARAMETERS SOMEWHAT DIFFERENT THAN ILLUSTRATED ON THIS PLAN. IN ORDER TO INSURE COMPLIANCE, CONSULT THE LOCAL WEIGHTS & MEASURES OFFICE PRIOR TO CONSTRUCTION.
4. REFER TO SCALE MANUAL FOR INSTALLATION AND OPERATION INSTRUCTIONS.
5. A MINIMUM OF 24" OF CLEARANCE IS REQUIRED ON JUNCTION BOX SIDE OF THE SCALE NEAR THE BOX MOUNTS.

FOUNDATION CONCRETE REQUIREMENTS 4000 P.S.I.	
AREA	QUANTITIES
PIERS AS SHOWN	12 CU. YD.
APPROACHES	7 CU. YD.
FLOOR AT 2" THICK	5 CU. YD.
TOTAL	24 CU. YD.

FOUNDATION REINFORCING BAR SCHEDULE ASTM A615 GRADE 60					
MARK	NO.	REQ'D.	SIZE	LENGTH	WT.
HR1	113	#4	11'-6"		868
HR2	120	#4	3'-0"		241
HR3	24	#4	9'-6"		152
VR1	48	#4	2'-6"		80
TOTAL WT:					1341

REINFORCING STEEL NOTES:

1. REINFORCING STEEL SHALL BE FREE OF ALL MUD, DEBRIS, CEMENT GROUT, LOOSE RUST, GREASE, AND OIL.
2. TACK WELDING OF BARS IS PROHIBITED.

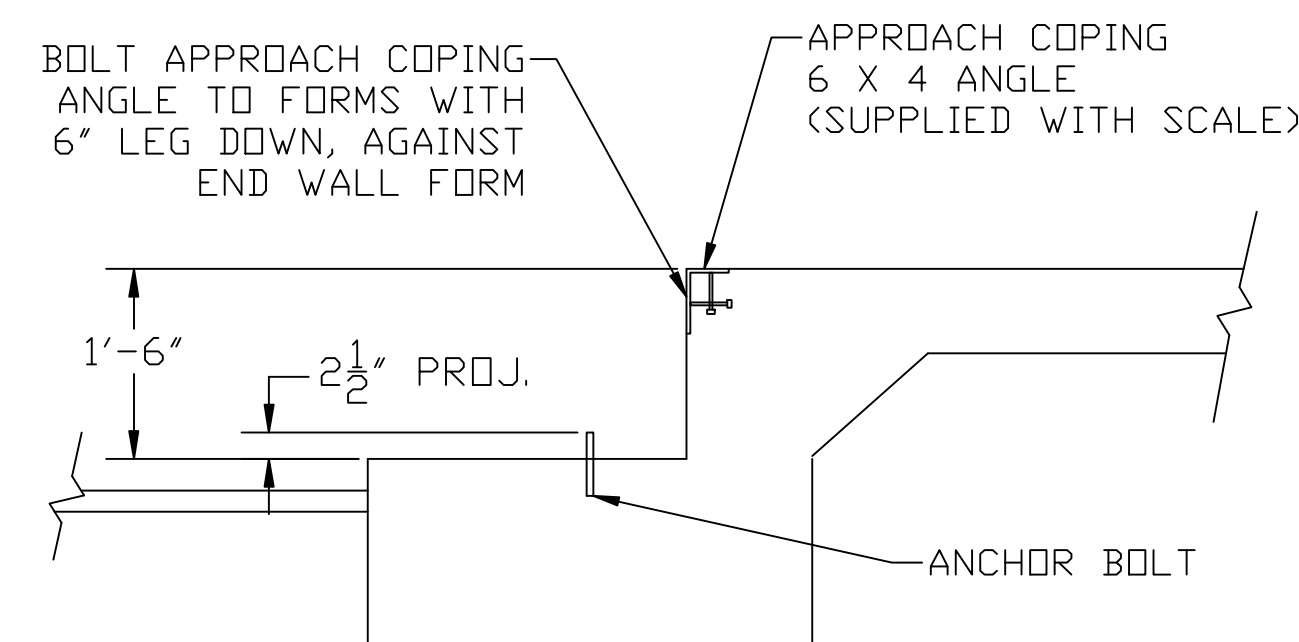

DRILL TYPE ANCHOR INFORMATION  
(DRILL TYPE ANCHORS PROVIDED WITH THE SCALE)

FOR THE LC STANDS (20 REQUIRED)  
5/8 DIA X 6" STUD TYPE ANCHORS  
DRILL DIA 5/8", DRILL DEPTH 3 1/2"

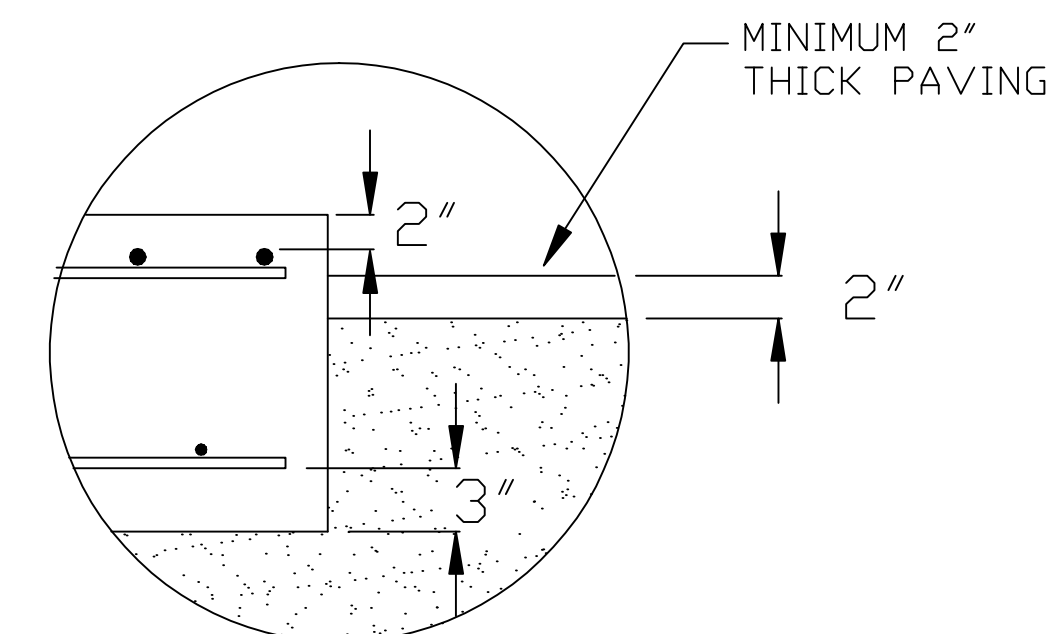

THIS DRAWING IS SUPPLIED AS CHECKED BELOW:

- REFERENCE (ESTIMATES ONLY, NOT FOR CONSTRUCTION)
- CERTIFIED FOR CONSTRUCTION, THURMAN#
- CUSTOMER: \_\_\_\_\_ DATE: \_\_\_\_\_
- CUSTOMER P.O.# \_\_\_\_\_
- CUSTOMER APPROVAL, RETURN ONE COPY. (ORDER ON HOLD UNTIL SIGNED COPY IS RETURNED)
- APPROVED AS DRAWN, APPROVED BY: \_\_\_\_\_ DATE: \_\_\_\_\_
- APPROVED AS NOTED, APPROVED BY: \_\_\_\_\_ DATE: \_\_\_\_\_

TOLERANCES (UNLESS OTHERWISE SPECIFIED) ± 1/8"

DIMENSIONS ARE IN INCHES UNLESS OTHERWISE SPECIFIED)

THIRD ANGLE PROJECTION

DATE: 9/4/09  
DRAWN BY: NDC



255 E. LIVINGSTON AVE.  
COLUMBUS, OHIO 43215  
PH: (614) 221-9077  
FAX: (614) 221-8879

This drawing is the property of Thurman Scale Company and is loaned to the recipient for his/her confidential use only. In consideration of the loan of this drawing, the recipient promises and agrees that it shall not be used in any way detrimental to the interest of Thurman Scale Company, that it shall be returned upon request, and that it shall not be reproduced, copied, loaned or otherwise disposed of, directly or indirectly, without the express written consent of Thurman Scale Company.

TITLE  
8560 DIAMONDBACK 90K CLC 80' X 12' FOUNDATION (5 SECTION, DB LC)

DRAWING NUMBER 145025-FT REV