

REINFORCING STEEL SCHEDULE				
USE ASTM A615 GRADE 60 MIN. DEFORMED REINFORCING STL ALL BENDING MUST COLD FORMING				
ITEM	QTY	DESCRIPTION	LENGTH	WEIGHT
			A B C	
1	48	#5 STRAIGHT	31'-6"	1576
2				
3	10	#5 STRAIGHT	14'-6"	152
4	8	#4 STRAIGHT	14'-6"	78
5	30	#4 STRAIGHT	2'-3"	45
6	30	#4 BENT	2'-6" / 2'-6"	100
7	60	#4 STRAIGHT	9'-6"	381
8	40	#4 STRAIGHT	14'-6"	387
9	5	#5 STRAIGHT	14'-6"	76

MATERIAL SUMMARY:
 CONCRETE: 57 CU. YDS
 W.W.M.: 830 SQ. FT. (W4/W4 4"/4" DR EQUIV.)
 REINF. STEEL: 2795 LBS.

- NOTES:
- FOUNDATION DESIGN IS BASED ON A MINIMUM SOIL BEARING CAPACITY OF 2000 LB/SQ. FT. FOR SOIL CONDITIONS WHICH DO NOT MEET THIS SPECIFICATION. CONSULT WITH THE THURMAN SCALE COMPANY.
 - THE FOUNDATION SHALL BE INSTALLED AT AN ELEVATION AND LOCATION TO INSURE ADEQUATE DRAINAGE AWAY FROM SLAB.
 - THE FOUNDATION SLAB SHALL BE PURED MONOLITHICALLY.
 - REINFORCING STEEL IS TO CONFORM TO ASTM A615 GRADE 60 SPECIFICATIONS.
 - CONCRETE OF 4000 PSI MINIMUM COMPRESSIVE STRENGTH WITH 5-7% AIR ENTRAINMENT IS REQUIRED FOR FOUNDATION.
 - TOP OF CONCRETE AT STAND LOCATIONS MUST BE LEVEL AND IN THE SAME PLANE WITHIN ±1/8 INCH.
 - EXCAVATION, FORMS, REINFORCING STEEL, AND CONCRETE FURNISHED BY OTHERS. FOUNDATION REQUIREMENTS VARY FROM STATE TO STATE. CHECK WITH LOCAL WEIGHTS AND MEASURES DIVISION BEFORE CONSTRUCTION.

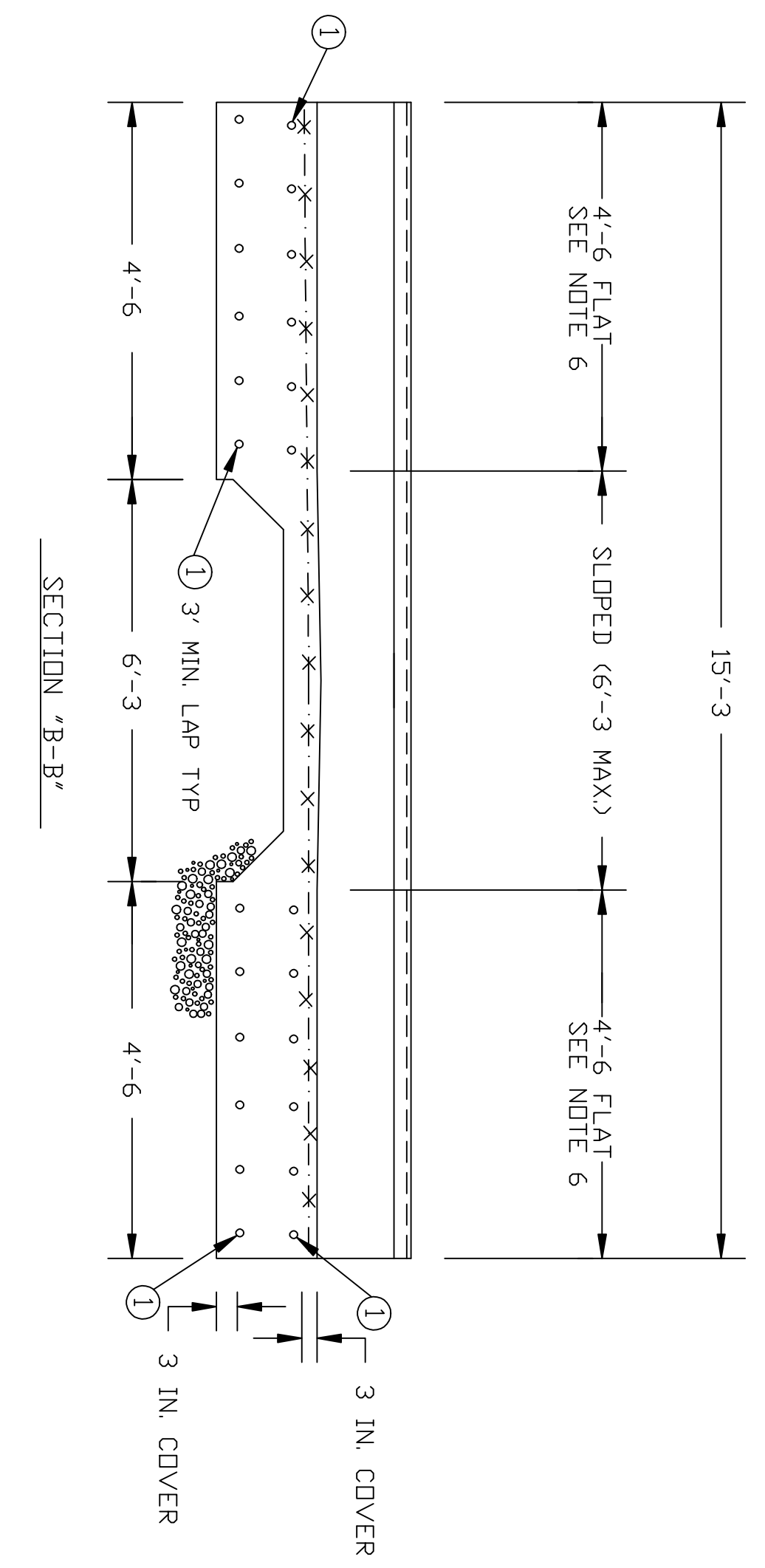

THIS DRAWING IS SUPPLIED AS CHECKED BELOW:

REFERENCE (ESTIMATES ONLY, NOT FOR CONSTRUCTION)
 CERTIFIED FOR CONSTRUCTION, THURMAN#
 CUSTOMER: _____ DATE: _____
 CUSTOMER APPROVAL, RETURN ONE COPY.
 ORDER ON HOLD UNTIL SIGNED COPY IS RETURNED.
 APPROVED AS DRAWN, APPROVED BY: _____ DATE: _____
 APPROVED AS NOTED, APPROVED BY: _____ DATE: _____

TOLERANCES UNLESS OTHERWISE SPECIFIED: ± 1/8"

DIMENSIONS ARE IN INCHES UNLESS OTHERWISE SPECIFIED

THURMAN
 255 E. LIVINGSTON AVE.
 COLUMBUS, OHIO 43215
 PH: 614 221-9079
 FAX: 614 221-9079

THIS DRAWING IS THE PROPERTY OF THURMAN SCALE COMPANY AND IS loaned to the recipient for his/her confidential use only. In consideration of the loan of this drawing, the recipient promises and agrees that it shall not be used in any way detrimental to the interest of Thurman Scale Company, that it shall be returned upon request, and that it shall not be reproduced, copied, loaned or otherwise disposed of, directly or indirectly without the express written consent of Thurman Scale Company.

TITLE: SLAB (3 SECTION, 6" PIPE LVR)
 DRAWING NUMBER: 92036-SL
 DATE: 10-03-02
 DRAWN BY: HAWKINS

For illustrative purposes ONLY - NOT for construction!