

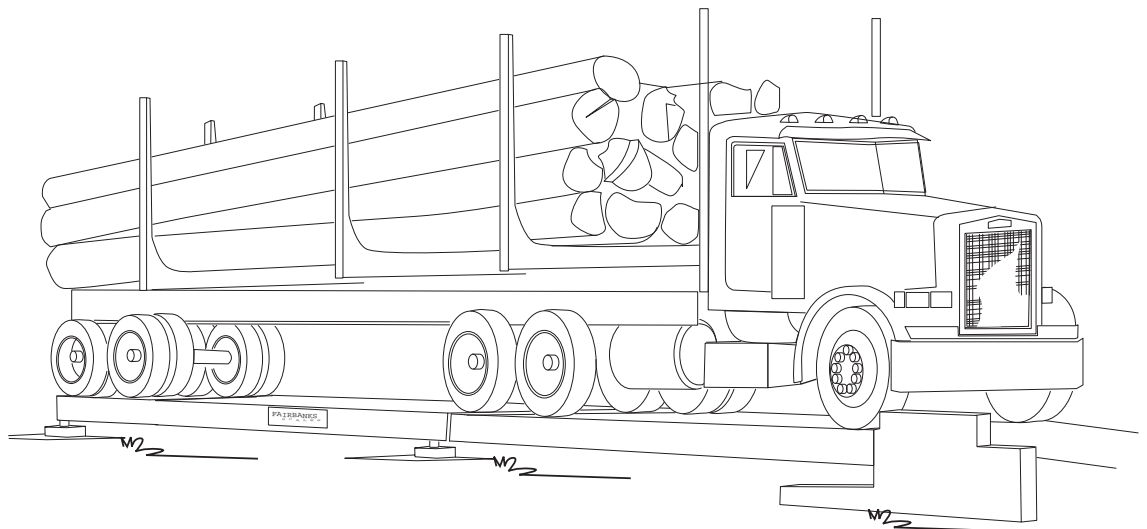

TITAN

Motor Truck Scale

Model: 6020 Series



Amendment Record

Titan 6020 Series Motor Truck Scale 50745

Manufactured by Fairbanks Scales Inc.
821 Locust
Kansas City, Missouri 64106

Issue #1	01/04	New product
Issue #2	09/05	Revised cable routing drawings; formatting
Revision 3	06/07	Updated the Parts List
Revision 4	07/07	Updated drawings and Parts Lists
Revision 5	03/10	Updated Specifications and drawings

Disclaimer

Every effort has been made to provide complete and accurate information in this manual. However, although this manual may include a specifically identified warranty notice for the product, Fairbanks Scales makes no representations or warranties with respect to the contents of this manual, and reserves the right to make changes to this manual without notice when and as improvements are made.

Table of Contents

Section 1: General Information	4
Section 2: Description	5
Section 3: Installation	
A. Preparations for Installations	7
B. Foundation	8
C. Setting the Modules	9
Section 4: Electrical Installation	
A. Introduction	14
B. Description	14
C. Installation	14
Section 5: Maintenance	
A. Scale Maintenance	17
B. Mechanical Faults	17
C. Replacing an RC Load Cell	17
Section 6: Parts List	
A. Parts List	18
B. Load Cells and Load Cell Hardware	18
C. O-Rings, Actual Size	19
Section 7: Accessories	
A. Field Installed Rub Rail Installation	20
<i>APPENDIX I: Foundation Check List</i>	21
<i>APPENDIX II: Wiring</i>	23

Section 1: General Information

This Instruction manual provides installation instructions for the Fairbanks **Titan Modular Steel Deck Truck Scales**.

For assurance of correct Titan scale installation(s), use:

- Methods and Procedures FF-2267 / 101732 (See Appendix.)
- The Certified prints/setting plans supplied with the scale
- This Instruction Manual, 50745

The concrete foundation work must be performed according to the certified prints issued for the specific customer and order number. The name and order number for the particular customer will be on the certified prints.

Section 2: Description

The Titan Modular Steel Deck truck scales are available in various lengths from 27 to 105 feet, and widths from 10 to 14 feet. The scale is made up of modules of 27, 30, and 35 feet in length. All modules are assembled and welded at the factory.

- The scale should be located so that vehicles can approach and exit the scale as easily as possible.
- The platform should be visible from the instrument location.
- Drainage of surface water must be such that water does not collect under the scale.
- Smooth and level approaches are required at each end of the platform to reduce loading shock and facilitate testing of the scale.
- Approaches must conform to the requirements of the law in the state in which the scale is being installed. In the absence of such laws, the approaches must conform to paragraph UR.2.6 National Institute of Standards and Technology Handbook 44, which states that the first 10 feet must be level and on the same plane as the scale platform.

NTEP CC: 96-089

CMA: AM-4949

Titan Steel Deck Truck Scale 6020 Series 100K CLC

Model	Scale	Weight	L feet	W feet	CLC Klbs	Cap tons	Sec
PLT-6020-T04	89801	12800	27	10	100	75	2
PLT-6020-T05	89802	14200	30	10	100	75	2
PLT-6020-T06	89803	16500	35	10	100	75	2
PLT-6020-T08	89804	28400	60	10	100	125	3
PLT-6020-T09	89805	33000	70	10	100	125	3
PLT-6020-T10	89806	38400	80	10	100	150	4
PLT-6020-T11	89807	42600	90	10	100	150	4
PLT-6020-T12	89808	49500	105	10	100	150	4
PLT-6020-U04	89809	14100	27	11	100	75	2
PLT-6020-U05	89810	15600	30	11	100	75	2
PLT-6020-U06	89811	18200	35	11	100	75	2
PLT-6020-U08	89812	31200	60	11	100	125	3
PLT-6020-U09	89813	36400	70	11	100	125	3
PLT-6020-U10	89814	42300	80	11	100	150	4
PLT-6020-U11	89815	46800	90	11	100	150	4
PLT-6020-U12	89816	54600	105	11	100	150	4
PLT-6020-V04	89817	15400	27	12	100	75	2
PLT-6020-V05	89818	17100	30	12	100	75	2
PLT-6020-V06	89819	19800	35	12	100	75	2
PLT-6020-V08	89820	34200	60	12	100	125	3
PLT-6020-V09	89821	39600	70	12	100	125	3
PLT-6020-V10	89822	46200	80	12	100	150	4
PLT-6020-V11	89823	51300	90	12	100	150	4
PLT-6020-V12	89824	59400	105	12	100	150	4
PLT-6020-W04	89825	18000	27	14	100	75	2
PLT-6020-W05	89826	19900	30	14	100	75	2
PLT-6020-W06	89827	23100	35	14	100	75	2
PLT-6020-W08	89828	39800	60	14	100	125	3
PLT-6020-W09	89829	46200	70	14	100	125	3
PLT-6020-W10	89830	54000	80	14	100	150	4
PLT-6020-W11	89831	59700	90	14	100	150	4
PLT-6020-W12	89832	69300	105	14	100	150	4

Section 3: Installation

Installation consists of the following:

- Foundation check, layout, and base plate setting
- Tools, materials, documentation, and a crane
- Setting the modules
- Setting the modules on load cells

A. Preparations for Installation: Tools, Equipment, and Materials Required

1. Certified Prints
2. A mobile crane of sufficient capacity to safely lift and place the weighbridge modules.
 - Approximate Steel Deck Module maximum weight: 8 tons.
3. Four (4) equal length (20 ft) lifting chains or cables with hooks to safely attach to the modules lifting channels located on the sides of the modules.

Note: The lifting straps MUST be requested in advance from the Crane Service Company.

4. Machinist's levels (Starrett # 134 & 132-6)
5. Hand tools
6. Hammer Drill with $\frac{5}{8}$ " bit, 16" long
7. Hydraulic jacks, 16 ton capacity
8. 100' steel tape measure
9. Stringline and chalkline
10. Prybars
11. High-quality grease and anti-seize
12. Load cell locating tools, Part No. 707118

B. Foundation:

Before installing any part of the scale, the foundation must be checked for accuracy using Foundation Inspection, Field Check List, FF-2267 / 101732 (see Appendix).

1. Layout and position the base plates in the proper locations using the Methods & Procedures and certified prints. Each base plate must be level and in full contact with the top of the pier. Adjustments can be made by chipping the concrete or grouting under the base plates.
2. Re-check the locations of each base plate against the certified prints. Insert two 1/2" roll pins into each base plate for anti-rotation. Position the plates with pins towards the outside. This will leave the load cell cable exiting the load cell to the inside. It is not necessary to install base plate anchors at this time.
3. Grease and install the inner O-ring in each load cell receiver cup. On all load cell receiver cups, grease the large outer O-rings, then install one in the groove on the outside of each cup. Put a 1/8" shim on the lower cups, grease the outside, then insert the shim(s) into the base plates. Lower cups for the load cells have a pin which must be aligned between the two roll pins in the base plate.
4. Place the upper cup with greased O-ring on the edge of the the upper foundation next to each base plate.
5. Place the load cell locating tool next to each base plate.

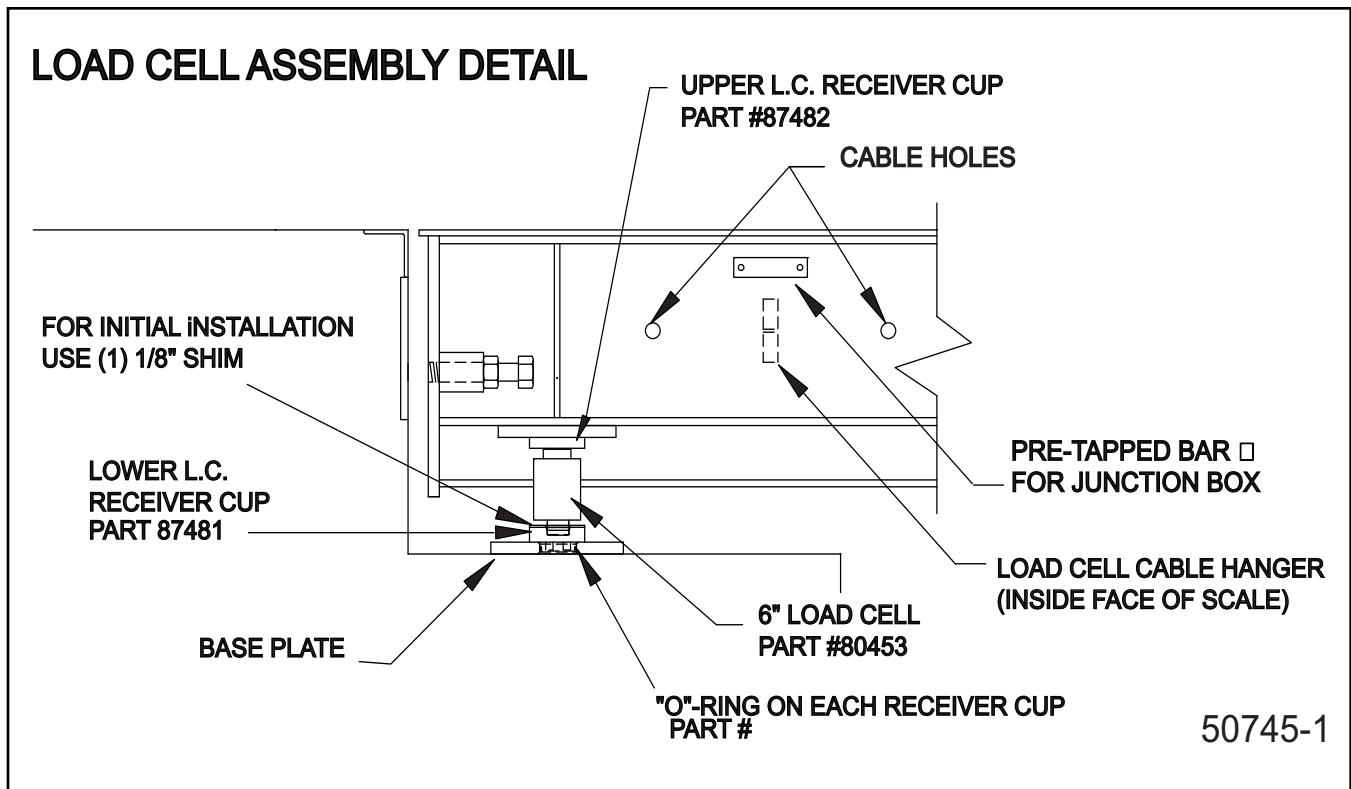

C. Setting the Modules

1. Preparing The Modules For Lifting

- The module(s) are complete with channel pieces welded to the sides for attaching lifting hooks. No lifting bolts are required.

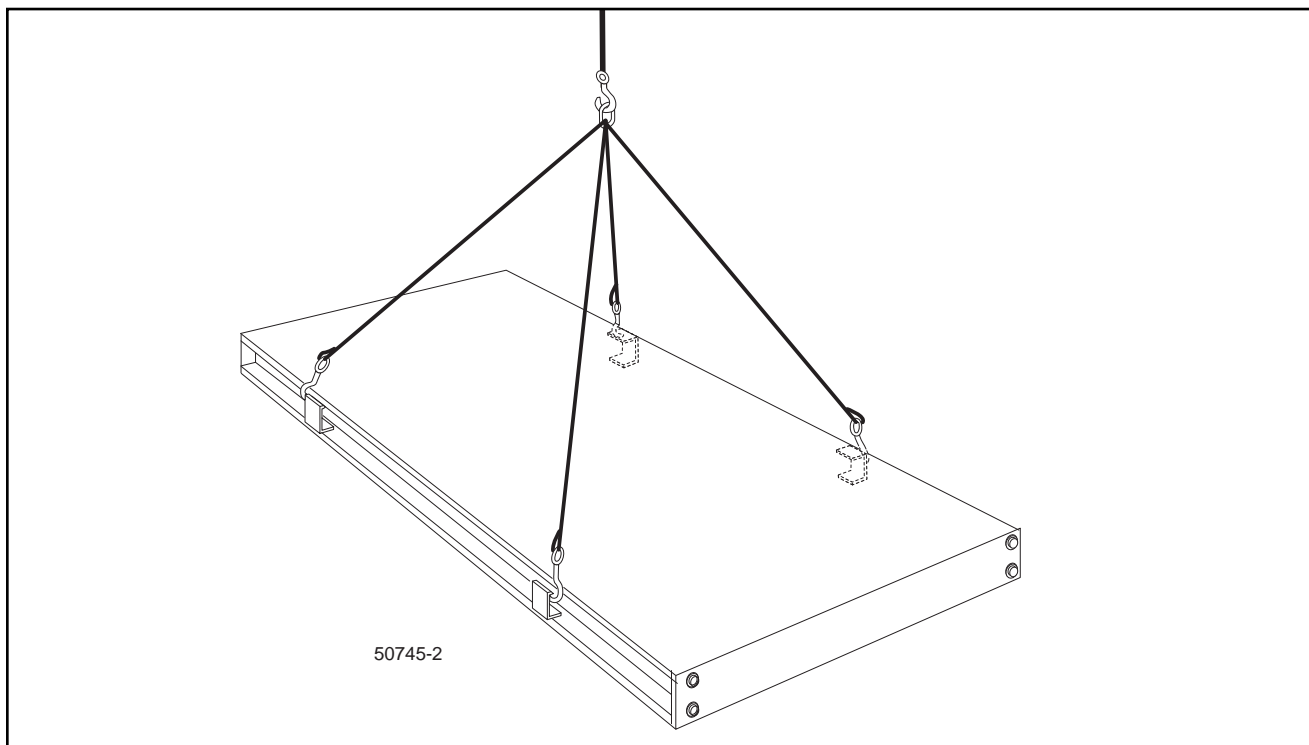

2. Setting the Center or Base Module:

- a. The center or base module is always set first. The center or base module will have four (4) load cells to install; all other modules will have two (2) load cells. The modules must be placed in the proper order and aligned in the foundation so that all modules fit correctly.
- b. These scales HAVE a definite orientation because of the junction box mounts are welded to one (1) side only. The junction box mount side of the base module should face the conduit of the main interface /homerun cable.
- c. Place the safety blocks under the modules, which will set the modules at a height slightly lower than the finished height.
- d. Lift the center or base module to a location above the four load cell base plates.

OPTION 1:

Set the module directly on the locating tools and the blocks will act as safety stands.

- Install a load cell bearing cup with "O" rings into the upper receiver of each corner on the module. Grease will help hold the cup in place.
- Insert the upper end of the locating tool into the upper cup on the module.
- Lower the module while holding the locating tool upright and guiding the bottom of the tool into the lower cup.
- When the base module is set on all four locating tools, keep tension on the cables until the module is centered and straight.
- Use hydraulic jacks to lift the unit slightly and shift the base plates to get the locating tools plumb and the top and bottom flanges flush with the sides of the cup.

OPTION 2:

Set the modules on the blocks first, then on to locating tools.

- The module is set on the blocks, keep tension on the cables until the module is properly aligned.
- Use hydraulic jacks to lift the unit slightly, then install the locating tools. Shift the base plates to get the tools plumb and the top and bottom flanges flush with the sides of the cup.
 - e. Measure from each side of each end of the module, to the end walls, to be certain the module is plumb and square before removing tension.
 - f. Once the tension on the lift cables is released, remove the lift brackets and/or hooks.

3. Setting End Modules

- Module Placement - Guide the modules into place with the supporting blocks on the end of the module coming to rest on the supporting blocks of the center module. Lower the other end of the module onto the load cell locating tools or blocks.

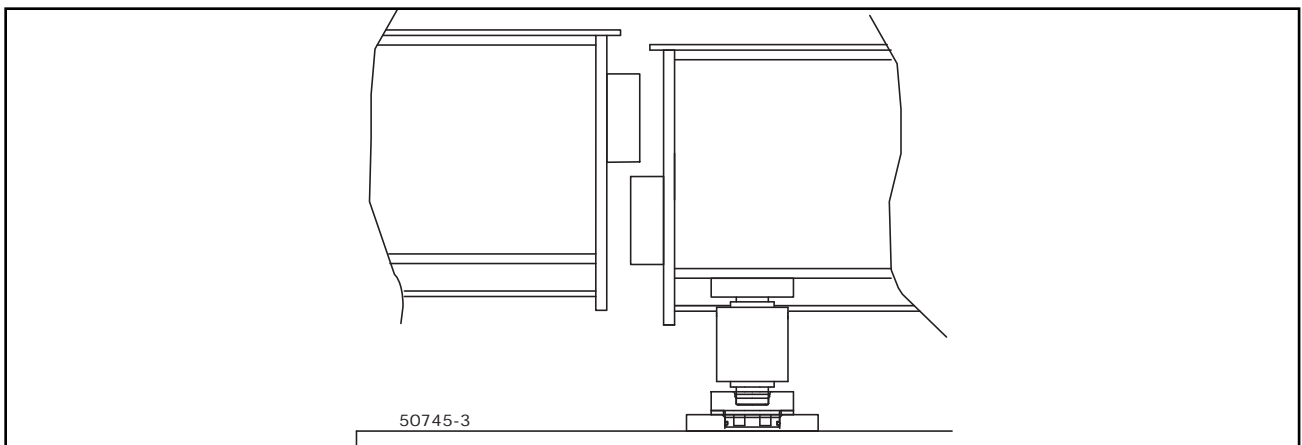

4. Before releasing cable tension

- Check the alignment of the end modules to the center or base module and to the end wall.
- Using the provided shims, fill any gaps on the supporting blocks and get the modules properly aligned.

5. Connecting the Modules:

- Bolt the modules together using the 1 $\frac{1}{8}$ " x 8" threaded rod, lock washers, flat washers and nuts provided. Tighten the bolts snugly, but do not tighten them completely. Shim the supporting blocks, if necessary, to align the modules.

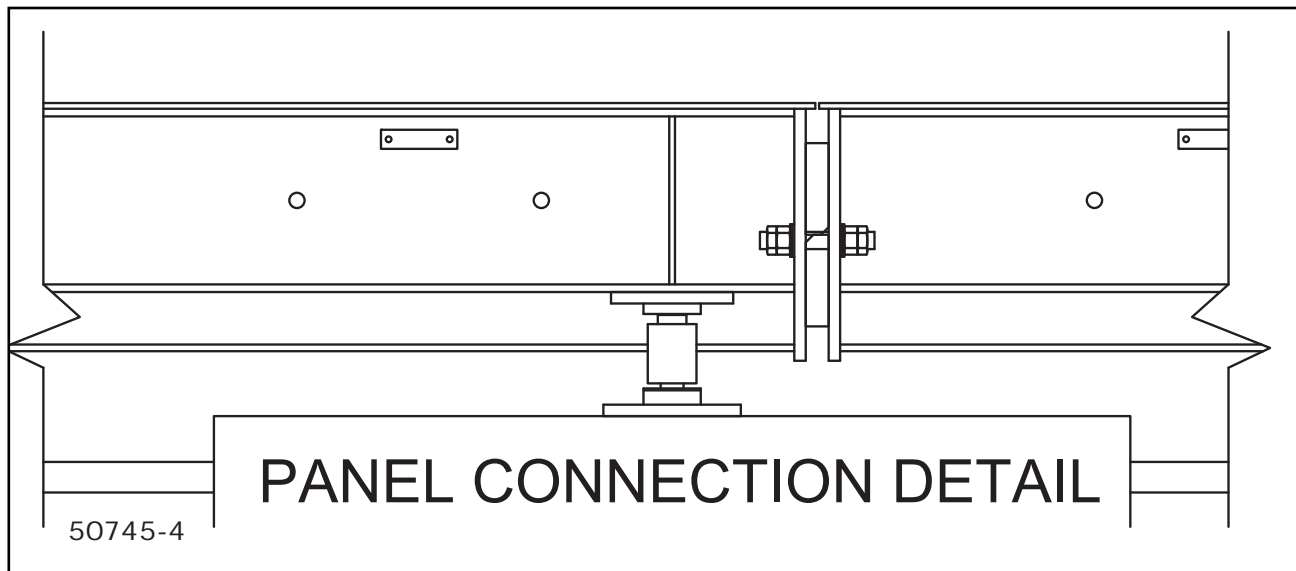

**** Warning ****

Module-to-module bolts **MUST** be installed correctly and torqued properly after all lifting is completed. **Do Not** substitute or omit bolts.

6. Checking Adjustment

a. Adjust End Checking

- Adjust the End Checking Bolts until they touch and prevent movement.

b. Install the side checking brackets:

- Bolt the brackets to the end checking plates embedded in the end walls per certified prints. Adjust the bolts until they touch the channels they bump against.

7. Base Plate Completion:

- Check that all locating tools are properly aligned and flush with the receiver cups. Drill the holes for the base plate anchors using a hammer-drill and the $\frac{5}{8}$ " drill bit. Tap the anchors into clean holes and tighten the nuts securely.

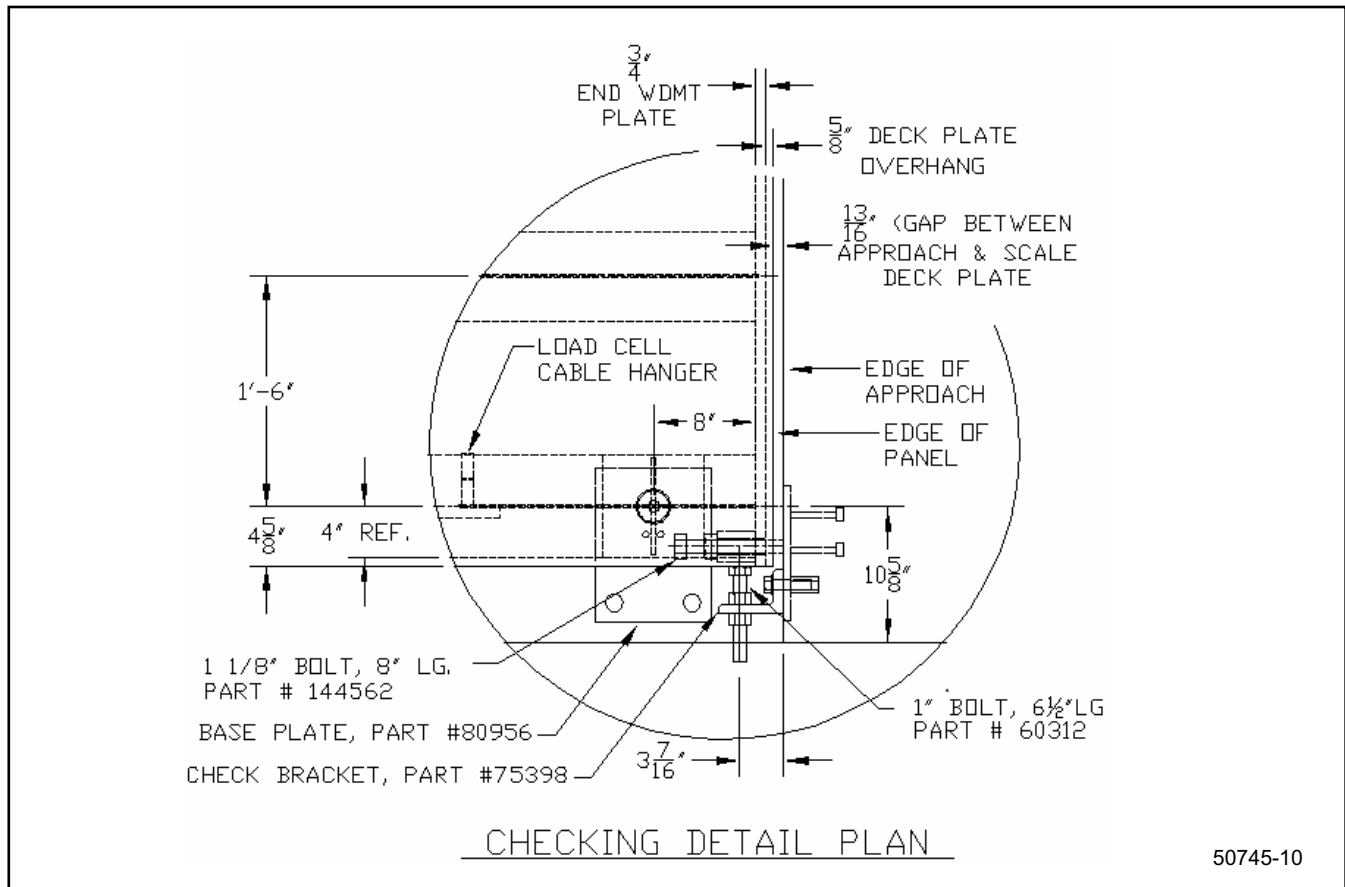

CAUTION!

Use eye protection!

8. Installing Load Cells:

- Unpack the load cells and mark each calibration certificate with the cell location/position.
- Starting at one end of the assembled platform, place hydraulic jacks at the corners so the section can be lifted off the locating tool. Two (2) hydraulic jacks may be required.
- Lift the platform so the load cell locating tool can be removed from the upper and lower bearing cups. Once removed, fill both cups with grease.

- d. On the bottom of the load cells there are two flatsides which must be aligned with the flats in the lower cup. Carefully lower the scale while seating the bottom of the cell into the lower cup. Check the scale's level and height, particularly at the approaches. Use the load cell shims provided to adjust load cell cups for correct height and to ensure that all cells share the proper amount of load. Center section cells will have up to twice the deadload of end section cells.
- e. When the modules are level and at the correct height, tighten the module-to-module bolts.
 - The bolts should be torqued to 500 ft lbs.
- f. Load cell cables:
 - Route the load cell cables to the conduits that go through the scale and also over the top of the module diaphragm plates. Coil excess cables on the cable hanger on the interior side of the I-beams (see Image 50745-11).

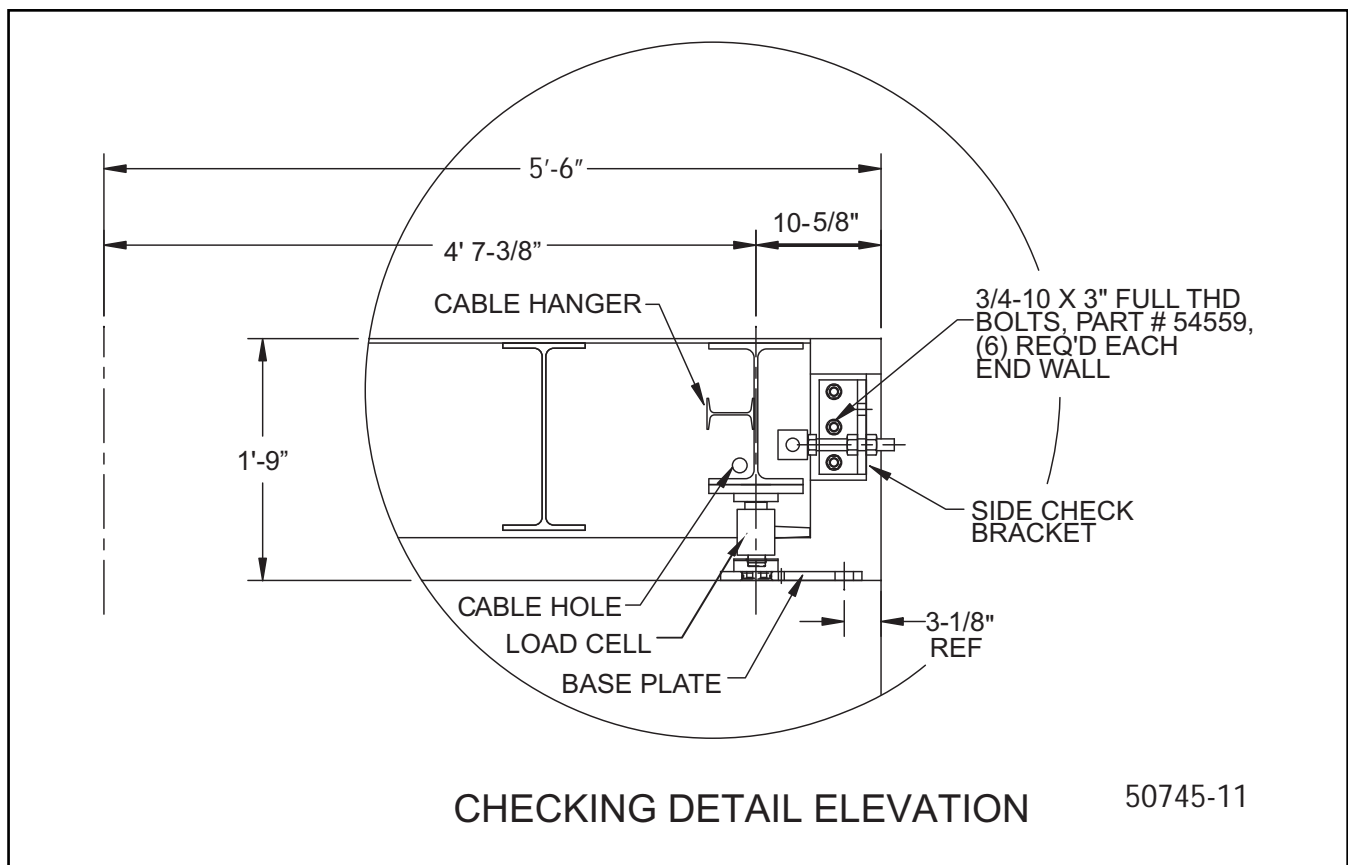

9. Final Checking Adjustment:

- a. Adjust End Checking
 - Adjust the End Checking Bolts to allow $1/16$ " to $1/8$ " clearance.
- b. Adjust side checking bolts to allow $1/16$ " clearance from block.

Section 4: Electrical Installation

A. Introduction

The Titan scale was designed to be used with Intalogix™ systems. Intalogix™ systems utilize smart sectional controllers (SSC) and pit power supplies (PPS) for load cell excitation and signal processing.

Analog instruments cannot be used with this platform. The sensitivity using an analog indicator would be approximately a half (.5) microvolt. Most analog instruments have a minimum sensitivity of one (1) microvolt.

B. Description

There is one (1) SSC per section and one (1) PPS for the entire platform unless the number and resistance of the cells require a second pit power supply. Smart sectional controller boxes have four (4) terminals: two (2) for load cells and two (2) for interfacing to other SSC boxes or terminating to a pit power supply. All cell/section/scale adjustments are made via the Intalogix™ system instrument.

C. Installation

a. Boxes

The box has mounting brackets which allow mounting to the side of the Titan modules.

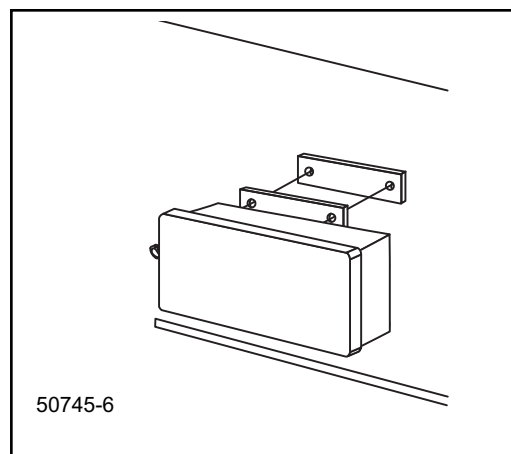

b. Wiring

Cable used in all wiring must be a minimum of 18 AWG. Use cable 17204 or 17246. Use appropriate service manual for the indicator being installed or refer to the Appendix for typical wiring information.

c. Smart Sectional Controller

Wire cells into each section's sectional controller per the appropriate service manual. Refer to the Appendix for typical wiring information.

Load Cell Wiring Designations

<u>Color</u>	<u>Description</u>
Black	(-) Excitation
Green	(+) Excitation
Red	(-) Signal
White	(+) Signal
Yellow	Shield

Note: *The Titan has been designed to provide protection from the effects of moisture. The load cells have been calibrated with the cable attached, and therefore the cable should NOT be cut. The cable is connected directly to the sectional controller through a sealed gland fitting which MUST be tightened properly to keep water and moisture out of the box. All cabling should have a drip loop at the cell or box entry location to help prevent water entry. On all boxes, the load cell cable gland fittings have O-rings that can be forced out of position if tightened improperly. To prevent this, first tighten the inner nut securing the gland in the hole, then insert the cable and carefully tighten the gland. Do not over-tighten where the gland turns. The cover MUST be secured with ALL screws tightened properly (10 in/lbs) for protection against moisture.*

Note: Smart Sectional Controllers have connections for two (2) load cells, TB1 and TB2. The odd numbered cell connects to TB1 and the even numbered cell connects to TB2.

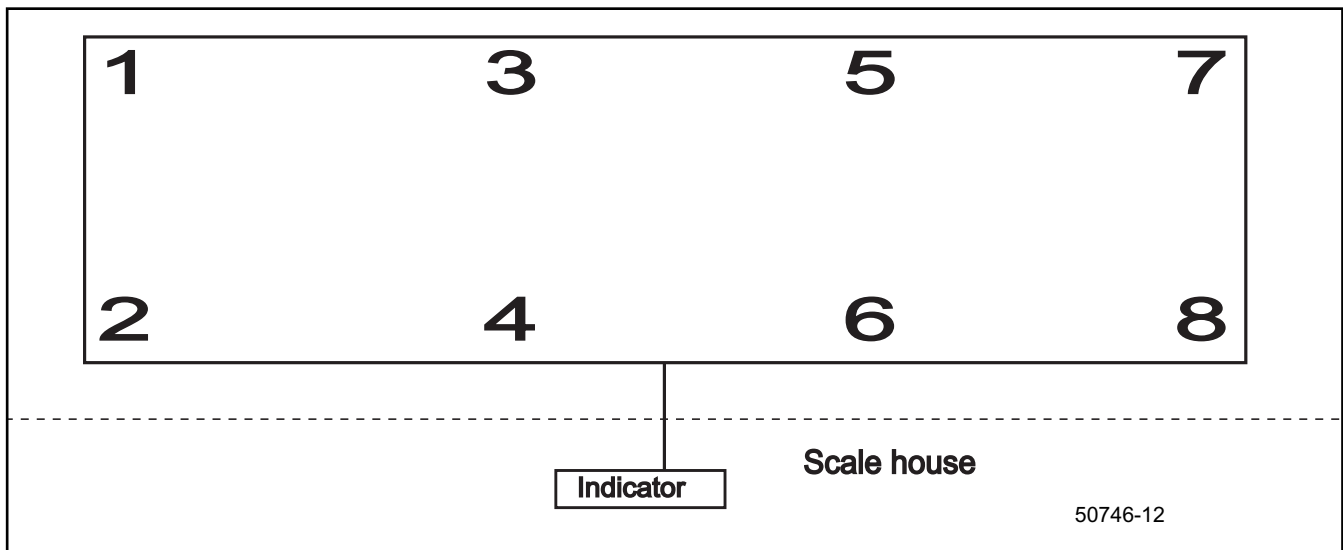

Note: Intalogix™ installations utilize a specific numbering system for load cells because of digital addressing of the SSCs.

Number the load cells as follows: With respect to the following starting position, face the platform from where the indicator is located. The cell at the upper left or far side of the platform is Cell 1. The cell positions along the far side will be odd cell numbers, the near side locations will be even cell numbers (see *Image 50745-12*).

CAUTION!

Improper grounding will prevent the surge voltage protection from adequately protecting the scale.

d. Grounding - Smart Sectional Controllers

Intalogix™ systems must have two (2) ground rods in the foundation for proper connection. Pit power supplies use a ground separate from the weighbridge ground rod.

e. Indicator to Pit Power Supply Cable Connection

Prepare the cable ends in the standard manner. Use the appropriate manual for wiring instructions for the sectional controllers and power supplies. Connect the indicator interface cable to the instrument in the scale house per the instructions in the appropriate indicator service manual.

Section 5: Maintenance

A. Scale Maintenance

1. Check for accumulations of solid material under the scale which may affect the accuracy, i.e., ice, frozen mud, debris.
2. Have the customer clean under the platform regularly.
3. Inspect load cells for damage to the ends/cables, check cups and O-rings for damage.
4. The load cell bearing cups should be inspected, cleaned and greased periodically.
5. Inspect and adjust all checking to proper tolerances.

B. Mechanical Faults

1. Check all clearances around the scale for any obstructions or interference with the movement of the platform.
2. Check all check bolt clearances, both with and without a concentrated load over each section, individually.
3. Check all load cells for plumb and level.
4. Inspect the boxes for leaks; the interior should be clean and dry. If there is moisture inside, clean, then dry it out thoroughly. Check all connections at the terminal blocks.

C. Replacing a load cell

1. Remove power from the instrument.
2. Lift the scale using a proper sized and rated hydraulic jack(s) at the corner(s) close to the defective cell location.
3. Check upper and lower receiving cups, and O-rings for damage. Replace as necessary and reapply grease.
4. Insert the new cell into the upper receiving cup & position the anti-rotation pin.
5. Carefully lower the hydraulic jack(s) until the cell is set into the lower cup.
6. Remove the cover of the sectional controller, then loosen the gland bushing to free the cable. Remove the old cell wires and connect new cell wires in the sectional controller. Latch the cover. Tighten all gland nuts with a wrench to secure.
7. Test and adjust scale as necessary.

Section 6: Parts List

A. Parts List

Part No.	Description
75458	1 1/8" - x 4 1/2" w/ nut (module - module)
54788	1 1/8" lock washer (module - module)
54255	1 1/8" flat washer (module - module)
80956	Load Cell Base Plate
61743	Clamp Bar Washer (base plates)
62857	5/8" x 6" Anchor Bolts
55010	Ground Rod Kit
144562	Check Bolt 1 1/8" x 8"
75398	Check Bracket
60312	Side Check Bolt 1" x 6 1/2"

B. Load Cells and Load Cell Hardware

Part No.	Description
80453	Load Cell, 6" RC, 100K, 1000 ohm, 2mv/v
73682	Shim, receiver cup, 1/16"
64338	Shim, receiver cup, 1/8"
64334	Shim, receiver cup, 3/16"
72274	"O" Ring, INSIDE of Cup, ANSI #222
64340	"O" Ring, OUTSIDE of Cup ANSI #228
87481	Receiver Cup, LOWER (w/ anti-rotation pin)*
87482	Receiver Cup, UPPER**
64382	Roll Pin, 1/2" x 2 1/2" anti-rotation, baseplate
63981	Anti-Rotation Pin, LOWER Receiver Cup 3/8" x 2 1/2"
107118	Locating Tool 6"

* If manufactured before 07/01/07, then order part no. 70511.

** If manufactured before 07/01/07, then order part no. 70512.

C. O-Rings, Actual Size

2 1/4" I.D.
2 1/2" O.D.
1/8" Thickness

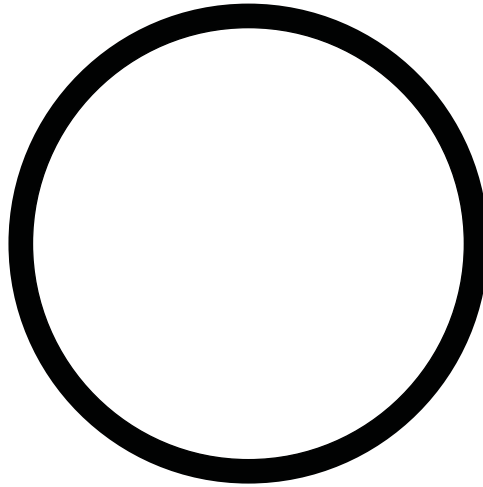

Part No. 64340
ANSI # 228
Outside of all
load cell cups

1 1/2" I.D.
1 3/4" O.D.
1/8" Thickness

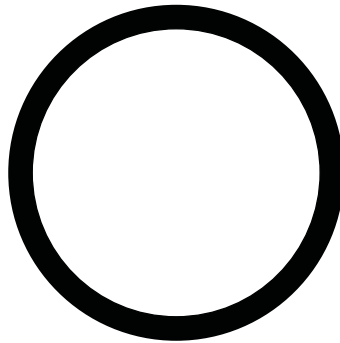

Part No. 72274
ANSI # 222
Inside of cup

50745-7

Section 7: Accessories

A. Field Installed Rub Rail Installation

- Disconnect all loadcells. Electrically isolate the load cells from the platform.
- Use the print with the accessory for actual measurements
- Clean (remove primer) the areas to be welded for good penetration.
- Weld stiffeners to the side weldments.
- Bolt the gussets to the stiffeners and end weldments.
- Weld pipe to the gussets.
- Clean and paint (paint provided) all weld areas.

** Warning **

Fairbanks does NOT recommend using foundation- or ground-installed guide rails along the sides of a truck scale platform. Damage may occur to the scale if a truck hits the guide rail, transferring damaging forces to the platform and the checking system.

Use of this style guide rail will void product warranty.

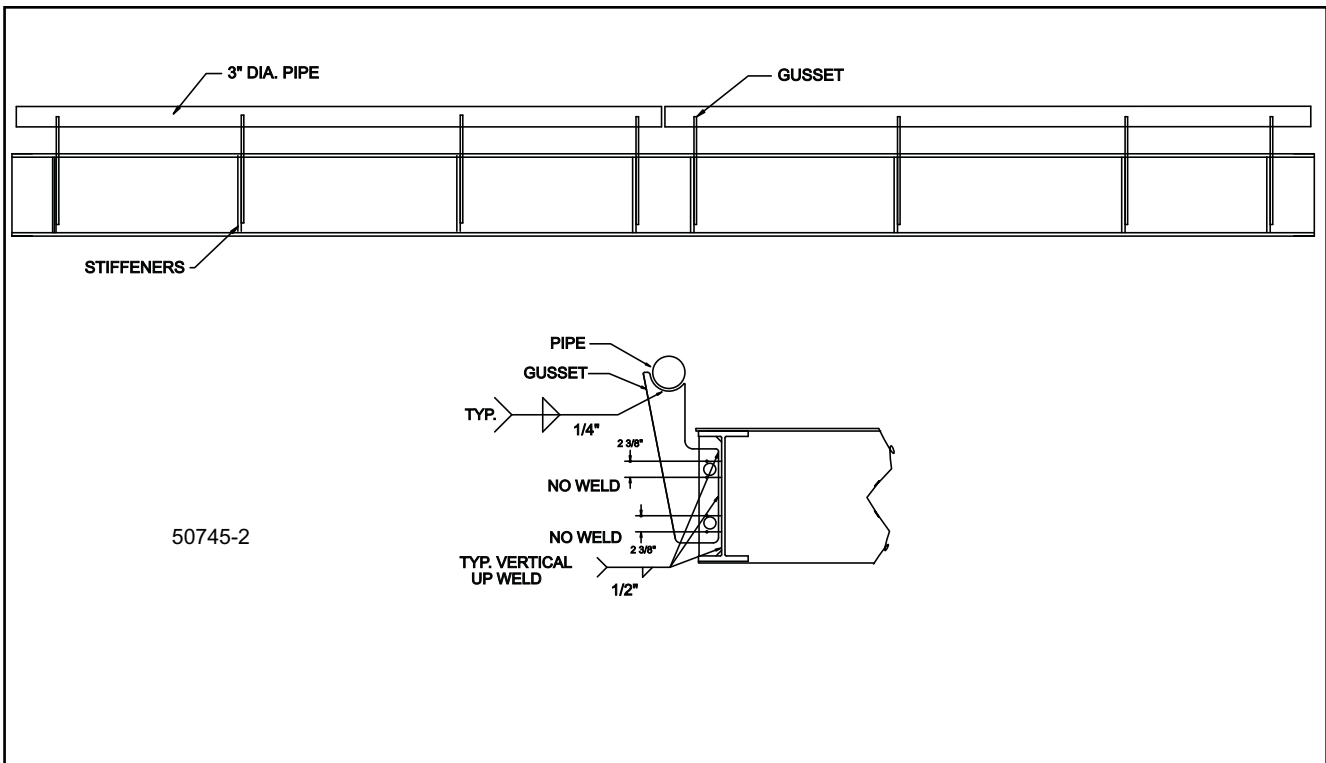

Appendix I: Foundation Check List



Foundation Inspection

FOUNDATION FIELD CHECK LIST (Field Form)

A Foundation Inspection **should ALWAYS** be performed prior to scale installation and to **confirm** correct foundation construction. If possible this should be done prior to scale shipment.

- Tools required:**
- Certified drawings and site plan
 - 2' to 4' level
 - 100' and 25' steel tapes
 - Hammer and concrete nails
 - Laser or builders level if possible
 - String line (construction string)
 - Straight edge for pit foundations (2 x 4, very straight and 4" wider than pit walls)
 - Construction paint (up-side-down type, for marking concrete).

Perform the following Foundation Checks. Refer to Methods and Procedures for complete description of each step. Recommended to copy check list and keep in job file. ALWAYS familiarize yourself with the **CERTIFIED** foundation prints for the job you are working on as model numbers and specifications are subject to change.

- 1. **Site Plan and Certified Prints** should be thoroughly reviewed to confirm accurate locations to the scale and all extra items (scoreboards, lights, poles, etc.) that are included in the bid or contract.
- 2. **Check for truck and crane access**, overhead wires, fences, green concrete, etc.
- 3. **Dimensional length and width check**; check all 4 sides and record on chart (other side).
- 4. **Diagonal measurements** check to verify that the foundation is square and record on chart (other side). These measurements should be equal, or within 1/2". Greater error could result in the scale not fitting in the foundation.
- 5. **Check ALL pier heights** to make sure they are the proper elevation and record on chart (other side). Too high and the scale will not fit correctly, too low could result in excessive shimming..
- 6. **In pit foundations check walls to verify they are straight.** Straight walls are very important, but are even more critical for modular scales like the **Titan Series**.
- 7. **Verify conduit locations** and pull strings (if needed).
- 8. **Verify ground rod locations.**
- 9. **Verify that drains and sump openings** are piped correctly and are clear of debris.
- 10. **Check the end coping** to ensure they are centerline and that the coping is correct for the scale being installed (10', 11' or 12' width, etc). Check all coping, side and end, for hollow areas.
- 11. **Verify location of any and all required embeds or pre-installed baseplates** (i.e., Hwy System, RR scales, etc). All of these dimensions will be located on the Certified foundation prints.
- 12. **Layout** - To help in locating pre-installed baseplates, embeds, load-cell centerlines, etc., refer to Methods and Procedures section on Layout. **See other side for foundation & Layout charts.**

FF-2267

Issue #1

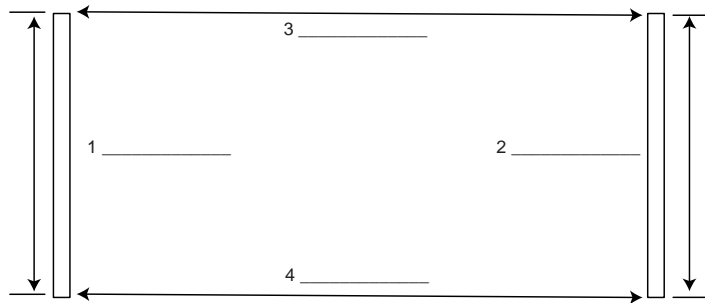

Length & Width Check

Diagonal Measurements Check

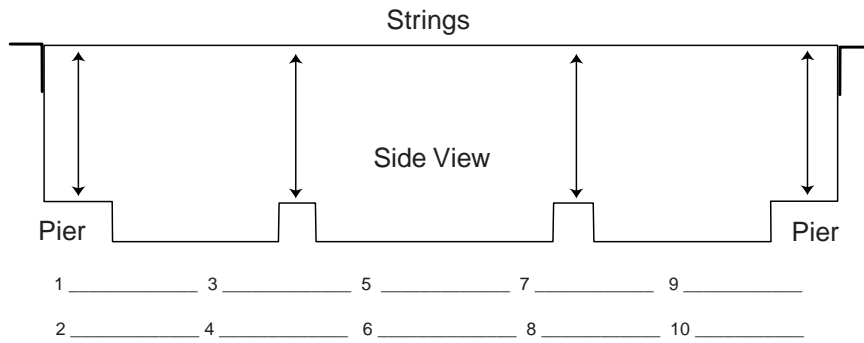
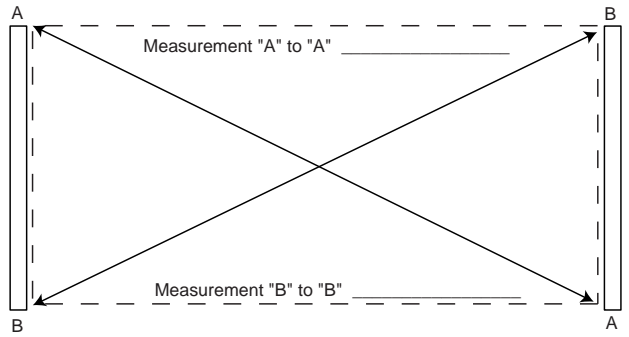

Pier Height Check

Longitudinal Layout

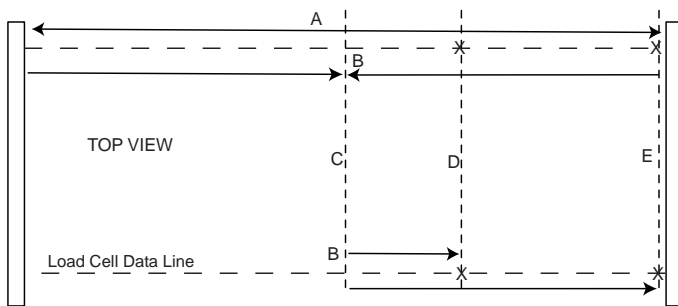
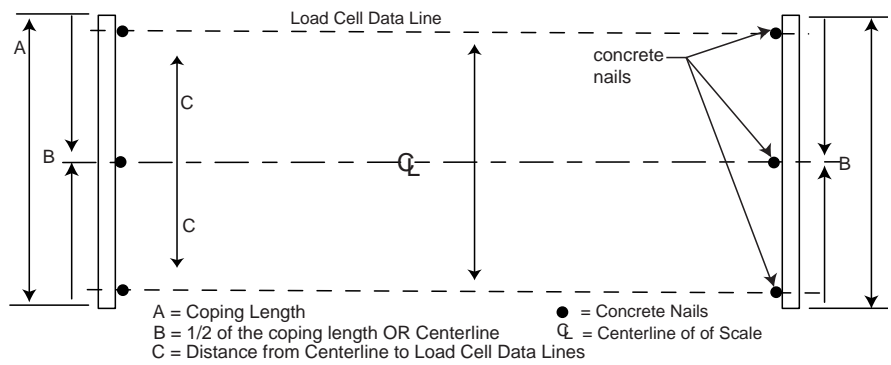

Lateral Layout

FF-2267

Issue #1

Appendix II: Wiring

S A M E

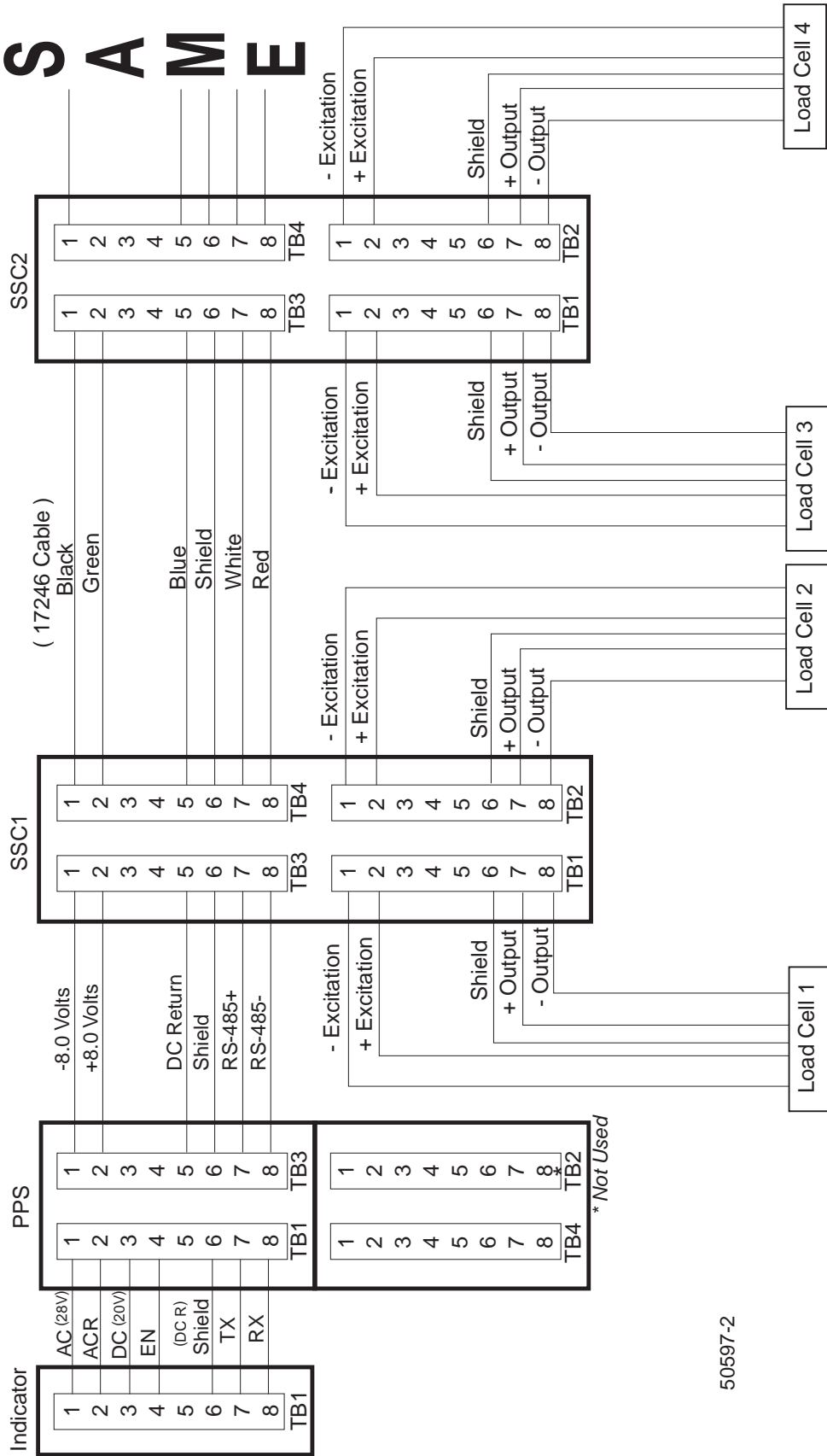

50597-2